

TMM

Miguel Milá, 1961

Floor lamp



ADI FAD
ORO 1961

2

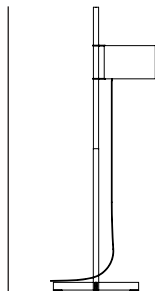

The most celebrated piece by one of the masters of Spanish design, the TMM is an exquisite demonstration of formal serenity and functional efficiency. A cross-shaped base supports a square shaft that becomes circular in the middle, allowing the shade to be moved up and down. A true manifesto of Barcelona's industrial design scene.

GENERAL DESCRIPTION

Cherry, wenge, beech, walnut or natural oak wood structure.

Height-adjustable lampshade in white (optional upper diffuser in white translucent engineering plastic) or beige cardboard. It is delivered with cable, bulb socket and fastening system to the structure.

Electric cable length: 4 m / 157.4".

LIGHT SOURCE

Recommended light sources:

LED bulb: 12 W

Compact fluorescent: 20 W

Incandescent: Max. 100 W

E27 - E26 (Max. hgt. 125 mm / 4.9")

Light source not included.

The light is switched on/off by pulling lightly on the cable.

Compatible with bulbs of the energy efficiency Class (E.E.C): A++... E. Lamp suitable only for indoor use.

Always use the light source recommended or equivalent.

Input voltage: 100, 120, 230 VAC.

(50 Hz / 60 Hz) According to destination.

* UL Market: Max.25 W for white lampshade with upper diffuser.

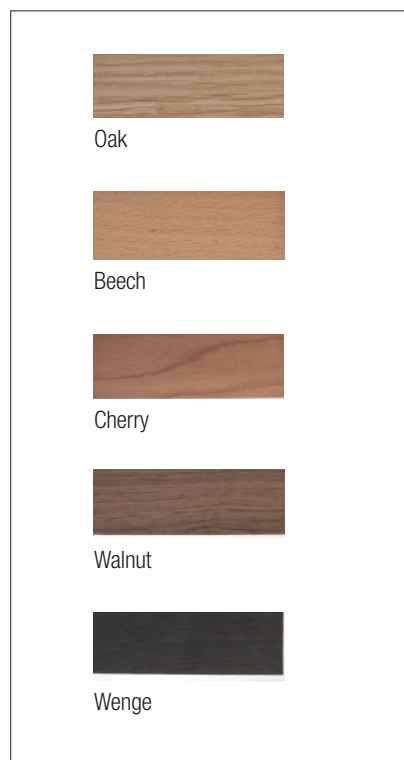

APPROXIMATE WEIGHT (unpacked)

4 kg / 8.8 lb

REGULATIONS

CE



IP 20

UNE-EN 60598

UNE-EN 55015

UNE-EN 60529



Non-class 2

Dry location only

UL-153

E-352592

MAINTENANCE

Clean with a smooth cloth. Do not use ammonia, solvent or abrasive cleaning products.

OTHERS

The lamp is delivered in different packages.

The assembly instructions are delivered with the product.

MODEL

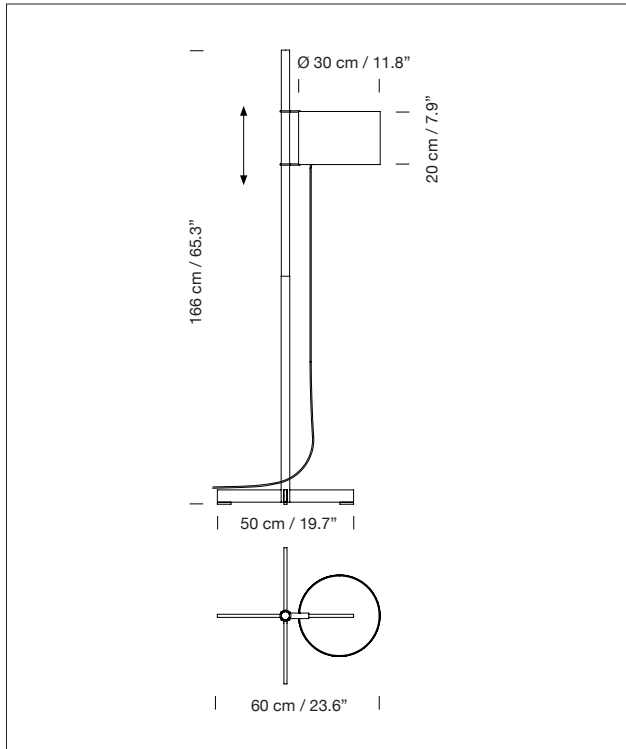

Collection

Wall lamps



TMM



TMM Metálico