

Grande personalità per questo divano dall'impatto morbido e tonico; il suo sentirsi al "centro" è determinato dalla sua forza che non è mai pesantezza. Il bracciolo profondo quanto lo schienale, i due cuscini di seduta leggeri perché dallo spessore ridotto e perché completamente in piuma, lo schienale leggermente obliquo che meglio accoglie i muscoli dorsali, le impunture sullo stesso, sono alcuni tratti caratterizzanti un divano molto comodo. La sua robustezza viene alleggerita e impreziosita dal profilo cromato alla base che "accende", porta luce alla parte bassa, mentre i piedini, nascosti perché posizionati in profondità, lo sollevano da terra quasi magicamente.

Great personality for this couch with a soft and tonic impact. Its feeling of being at the centre of attention is determined by its strength, which never becomes overwhelming. The armrest, as deep as the backrest, the two sitting cushions, light because they are thinner and completely stuffed with feathers, the slightly oblique backrest which comforts the back muscles, and the slight stitchings in the backrest itself, are just a few characteristics of this incredibly comfortable couch. Its robust nature is alleviated and embellished by the chromed profile at the base, which "turns on", brings light to the lower part, while the feet, hidden since they are positioned out of sight, lift it off the ground, almost as if by magic.

Grande personnalité pour ce canapé à l'impact délicat et tonique ; sa force, jamais synonyme de lourdeur, le met au « centre » de l'attention. L'accoudoir aussi profond que le dossier, les deux coussins légers de l'assise (peu épais et entièrement de plumes), le dossier légèrement oblique qui détend mieux les muscles du dos et les points de piqure sur ce dernier ne sont que quelques-unes des caractéristiques d'un canapé très confortable. Sa robustesse est allégée et enrichie par le profil chromé à la base qui lui donne luminosité, tandis que les pieds, cachés parce qu'en retrait, le soulèvent du sol comme par magie.

Dieses weiche, tonische Sofa hat einen absolut starken Charakter; sein Gefühl, immer im "Mittelpunkt" zu stehen, ist durch seine Kraft bedingt, die jedoch nie in Überheblichkeit ausartet. Die Armlehne mit der gleichen Tiefe der Rückenlehne, die beiden leichten, komplett mit Daune gefüllten Sitzkissen mit geringer Stärke, die leicht schräg gestellte Rückenlehne für die optimale Bettung der Rückenmuskulatur und ihre Steppnähte sind nur einige der Charakterzüge dieses ausnehmend bequemen Sofas. Seine Stabilität wird durch das verchromte Profil am Untergestell, das den unteren Bereich so zu sagen "ins Licht rückt", aufgelockert und veredelt. Die verdeckten Füße sind ganz tief eingesetzt, wodurch das Sofa wie durch Magie zu schweben scheint.

caesar

DESIGN: VANZANTEN























# caesar

DESIGN: VANZANTEN

L. BRACCIOLO	cm.33
L. BRACCIOLO POLTRONA	cm.18
H. BRACCIOLO	cm.54
H. SEDUTA	cm.41

 1 L. 105 - P. 101 - H. 73	 2MAX L. 215 - P. 101 - H. 73	 3 L. 245 - P. 101 - H. 73	 3MAX L. 290 - P. 101 - H. 73
 1D- L. 102 - P. 101 - H. 73	 1S- L. 102 - P. 101 - H. 73	 2MXD L. 182 - P. 101 - H. 73	 2MXS L. 182 - P. 101 - H. 73
 3D- L. 212 - P. 101 - H. 73	 3S- L. 212 - P. 101 - H. 73	 3MXD L. 257 - P. 101 - H. 73	 3MXS L. 257 - P. 101 - H. 73
 LGD L. 122 - P. 170 - H. 73	 LGS L. 122 - P. 170 - H. 73	 ANGQ L. 101 - P. 101 - H. 73	
 PFGP L. 115 - P. 60 - H. 39	 PFGD L. 90 - P. 60 - H. 39	 PFSM L. 75 - P. 60 - H. 39	 CSGR L. 55 - P. 55 - H. 7



\* STANDARD

B-050

TAB

Rivestimenti consigliati: collezione intera. - Rivestimento fisso standard.  
 Suggested cover: full collection. - Standard: fix covered.  
 Revêtement suggéré: tout la collection. - Revêtement fixe standard.  
 Vorschlag für den Bezug: gesamte Kollektion. - Standard fest bezogen.  
 Bekledingsvoorstel: gehele collectie. - Standard vast gestoffeerd.



# caesar

DESIGN: VANZANTEN

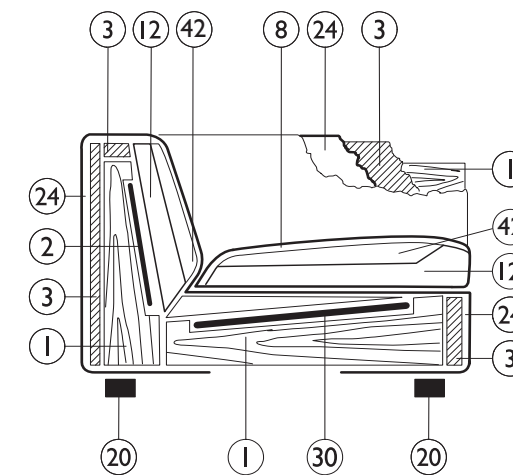

1-Solida struttura in legno. 2-Cinghie elastiche. 3-Poliuretano espanso. 8-Riempimento di piume stabilizzate a settori. 12-Poliuretano espanso pregiato RG 40. 20-Gambe di legno. 24-Fibra di poliestere accoppiata a cotone. 30-Telaio tubolare metallico con cinghie elastiche. 42-Imbottitura Visco foam.

1-Sturdy inner wooden frame. 2-Elastic straps. 3-Expanded polyurethane. 8-Padding with downs, stabilized in sectors. 12-High-grade expanded polyurethane RG 40. 20-Wooden feet. 24-Polyester fibre coupled with a cotton layer. 30-Tubular metallic frame with elastic straps. 42-Visco foam padding.

1-Solide structure in bois. 2-Sangles élastiques. 3-Polyuréthane expansé. 8-Garnis de duvet piquages en secteurs. 12-Polyuréthane expansé haute qualité RG 40. 20-Pieds en bois. 24-Fibre de polyester couplé avec coton. 30-Châssis métallique tubulaire avec sangles élastiques. 42-Visco foam garniture.

1-Stabiles Holzgestell. 2-Elastische Gurte. 3-Polyuretaanschium. 8-In Kammern unterteilte Daunenfüllung. 12-Hochwertiger Polyuretaanschium RG 40. 20-Holzfüße. 24-Polyesterfaser mit Baumwollauflage. 30-Metallrohrrahmen mit elastischen Gurten. 42-Visco foam Füllung.

1-Stabiele houten romp. 2-Elastische singels. 3-Polyuretaanschium. 8-In kamers verdeelde dons-vulling. 12-Hoogwaardige polyuretaanschium RG 40. 20-Houten poten. 24-Polyestervezels met katoendek. 30-Metalen buizen frame met elastische singels. 42-Visco foam vulling.

**OPZIONI-OPTIONS-OPTIONEN**

**B-050** Basamento tubolare metallico cromato - Tubular steel feet of chromium plated steel  
 Socle en acier chromé - Stahlrohrfüßgestell verchromt - Verchroomt stalen frame

**TAB** Tavolo in Plexiglas - Plexiglas table - Table in Plexiglas - Plexiglas Tisch - Plexiglas Tafel