

PH Artichoke Glass Ø 480

louis
poulsen

Design Poul Henningsen

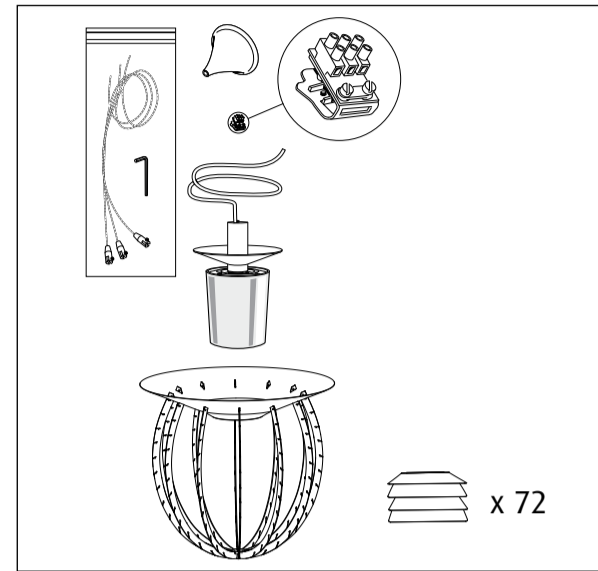
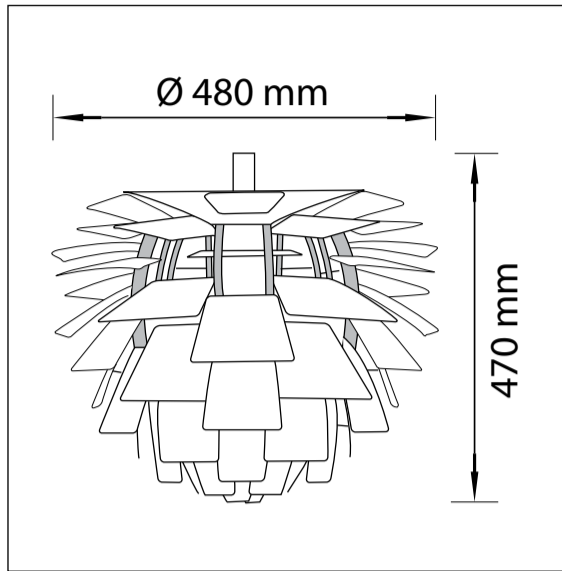

3603994-11

Lyskilde Light source Leuchtmittel Ljuskälla Sorgenti luminose Source lumineuse Fuente de luz Valonlähde	Spænding/frekvens Voltage/frequency Spannung/frequenz Spänning/frekvens Tensione/frequenza Voltage/frequence Tensión/frecuencia Jännite/taajuus	Vægt Weight Gewicht Vikt Peso/ingombro Poids Peso Paino	Isolationsklasse Electric shock protection Schutzklasse Isolationsklass Classe di isolamento Protection au choc électrique Clase de aislamiento Eristysluokka	Tæthedsklasse Ingress protection Schutzart Kapslingsklass Grado di protezione Indice de protection Clase de protección Koteloitiluokka
1x100W E27	 Max 220-240V/50-60Hz	Max 10,9 kg	Cl. I	IP20

DA

Skal rengøres i kold tilstand. Støv fjernes ved hyppig brug af luft på dåse. Fedtpletter og lignende kan fjernes meget nænsomt med en blød klud opvredet i lunkent vand (<50°C), tilsat mildt rengøringsmiddel, eller med sprit. Brug aldrig rengøringsmidler med slibemiddel eller opløsningsmidler.

EN

Must be cleaned in cold condition. Remove dust with frequent use of canned air. Remove greasy spots etc. very gently with a soft cloth dampened in lukewarm water (<50°C), with a mild detergent, or with alcohol. Never use detergents containing abrasives and solvents.

DE

Glas nur in kaltem Zustand reinigen. Staub bitte mit häufiger benutzung von Luftspray entfernen. Fettflecke und dgl. bitte sehr vorsichtig mit einem feuchten, in lauwarmem Wasser (<50°C) mit mildem Reinigungsmittel ausgewrungenen Lappen, oder mit Haushaltsspiritus, entfernen. Niemals Reinigungsmittel mit Schleifmittel oder Lösungsmittel verwenden.

SV

Ska rengöras i kallt tillstånd. Avlägsna damm regelbundet med tryckluft på burk. Fettfläckar och liknande tas bort mycket försiktigt med ljummet vatten (<50°C), utblandat med mildt rengöringsmedel, eller med sprit. Använd aldrig rengöringsmedel som innehåller slipmedel eller lösningsmedel.

IT

Deve essere pulito quando è freddo. Rimuovere la polvere con frequente uso di aria compressa. Rimuovere le macchie di grasso ecc. delicatamente con un panno morbido inumidito in acqua tiepida (<50°C) e con un detergente leggero, o alcol. Non usare mai detergenti contenenti abrasivi o solventi.

FR

Doit être nettoyé à froid. Dépoussiérer régulièrement avec de l'air sous pression. Éliminer les tâches de graisse etc., très délicatement avec un chiffon humidifié à l'eau tiède et de detergent doux, ou avec alcool. Ne jamais utiliser de detergents contenant des abrasifs et des solvants.

ES

Limpiar en frío. Limpiar con paño seco y suave. Quitar manchas de grasa y otras con paño suave humedecido con agua templada (<50°C) con detergente poco agresivo. Nunca use detergentes que contengan abrasivos y disolventes.

FI

Pyyhi pölyt kuivalla pehmeällä liinalla. Poista rasvatahrat miedolla pesuaineella ja haalealla vedellä (<50°C) kostutetulla pehmeällä liinalla. Älä koskaan käytä liuottimia tai hankausaineita sisältäviä pesuaineita.



DA

Louis Poulsen A/S fraskriver sig et hvert ansvar, hvis der anvendes en topforspejlet lyskilde. Denne type lyskilde kaster varmen tilbage og kan ødelægge/smelte dele af armaturet.



EN

Louis Poulsen A/S disclaims any liability if a half mirror light bulb is used. This type of light source reflects the heat and may damage/melt parts of the fixture.



DE

Die Louis Poulsen A/S haftet nicht, wenn eine Kopfspeigel lampe verwendet wird. Diese Art von Leuchtmittel reflektiert die Wärme, sodass Teile der Leuchte beschädigt werden können bzw. schmelzen.



SV

Louis Poulsen A/S fränsäger sig allt ansvar ifall en toppförseglad glödlampa används. Denna typ av ljuskälla reflekterar värmen och kan skada/smälta delar av armaturen.



IT

Louis Poulsen A/S declina qualsiasi responsabilità in caso di utilizzo di lampadine a cupola argentata. Questo tipo di fonte di luce riflette il calore e potrebbe danneggiare/fondere parti dell'apparecchio.



FR

Louis Poulsen A/S décline toute responsabilité en cas d'utilisation d'une ampoule à tête miroir. Ce type de source lumineuse réfléchit la chaleur et peut endommager/faire fondre certaines parties du luminaire.



ES

Louis Poulsen A/S rechaza toda responsabilidad derivada del uso de bombillas de cúpula espejada. Este tipo de fuentes de luz refleja el calor, como resultado de lo cual ciertas partes de la luminaria podrían sufrir daños o fundirse.



FI

Louis Poulsen A/S ei vastaa mahdollisista syntyneistä vahingoista mikäli valaisimessa on käytetty puolipeilitettyä valonlähdetä. Tämän tyyppinen valonlähde heijastaa lämpöä ja saattaa vahingoittaa/sulattaa valaisimen osia.

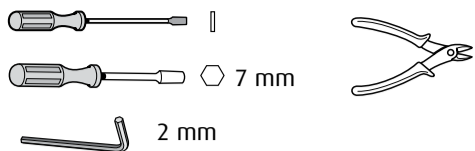
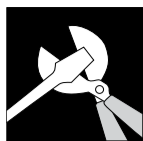

1

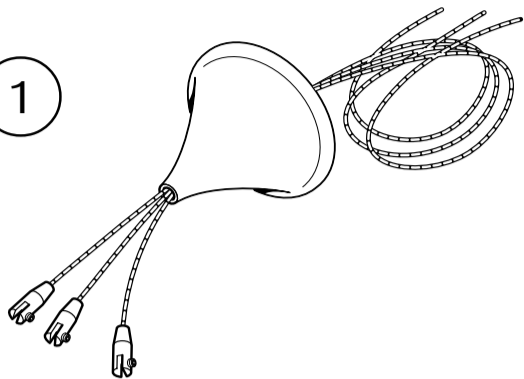

Minimum height

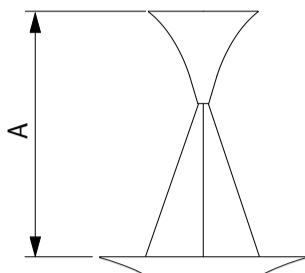

Artichoke Ø840 A = 650 mm
 Artichoke Ø720 A = 720 mm
 Artichoke Ø600 A = 700 mm
 Artichoke Ø480 A = 450 mm

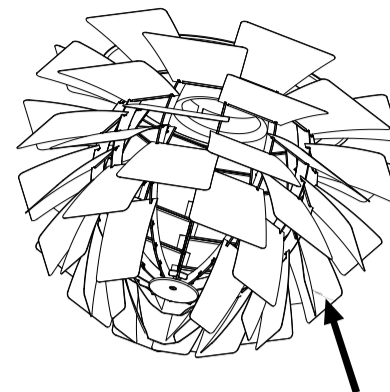

ID NUMBER: _____
 Please register ID number at www.louispoulsen.com

2

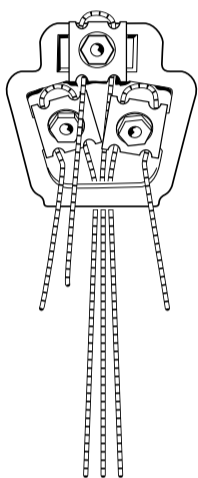

	L	⊕	N
DA	Brun	Gul/Grøn	Blå
SV	Brun	Gul/Grøn	Blå
EN	Brown	Yellow/Green	Blue
DE	Braün	Gelb/Grün	Blau
IT	Marrone	Giallo/Verde	Blu
FR	Brun	Jaune/Vert	Bleu
ES	Marrón	Amarillo/Verde	Azul
FI	Ruskea	Keltainen/Vihreä	Sininen
KR	브라운	옐로우/그린	블루
CN	褐色	黄色/绿色	蓝色

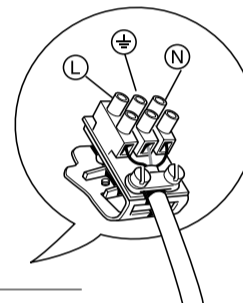

4

5

6

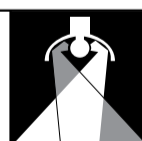
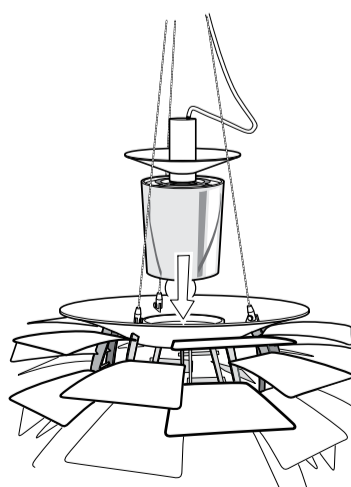
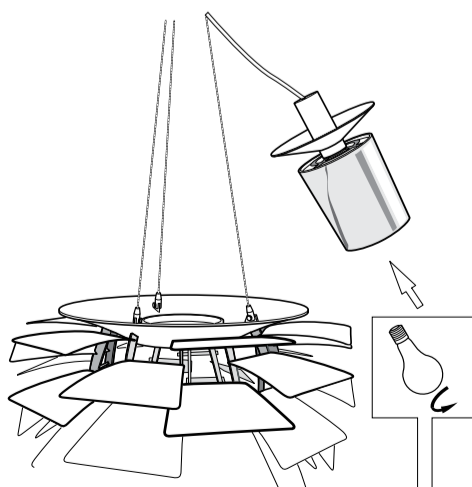
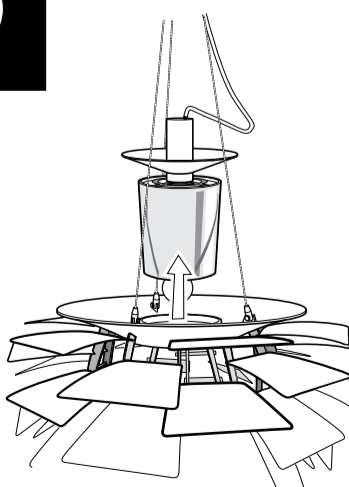
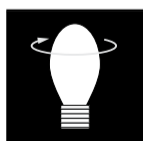
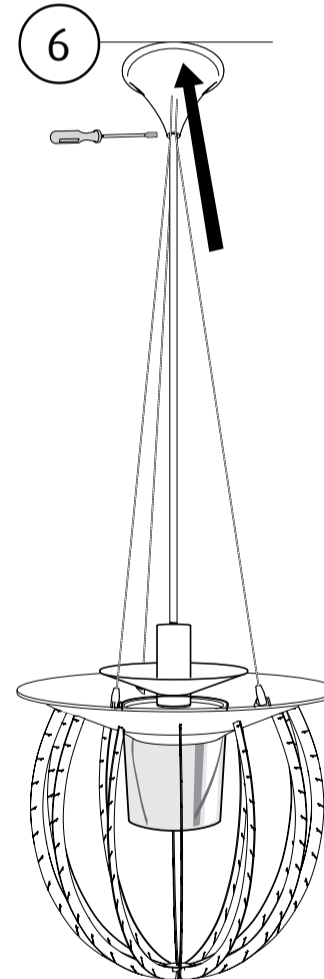
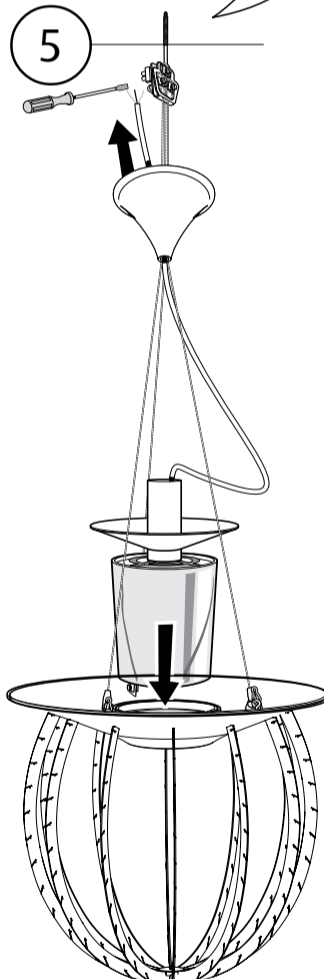
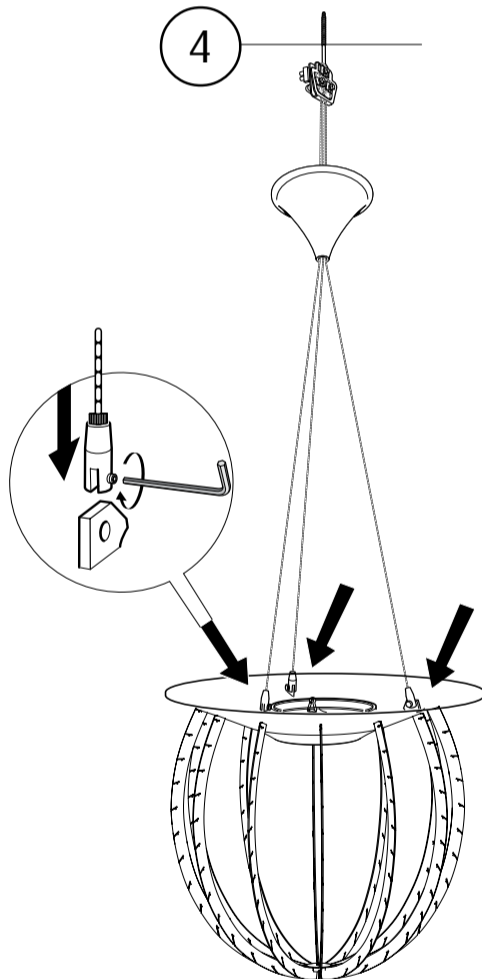
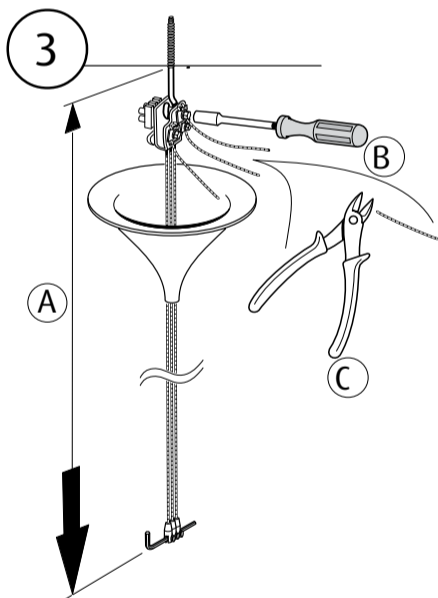

2 mm

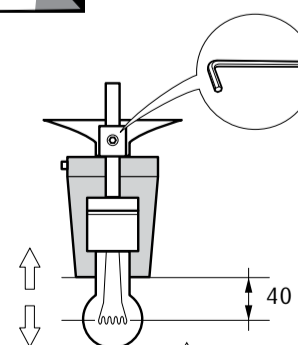

40 - 45 mm