

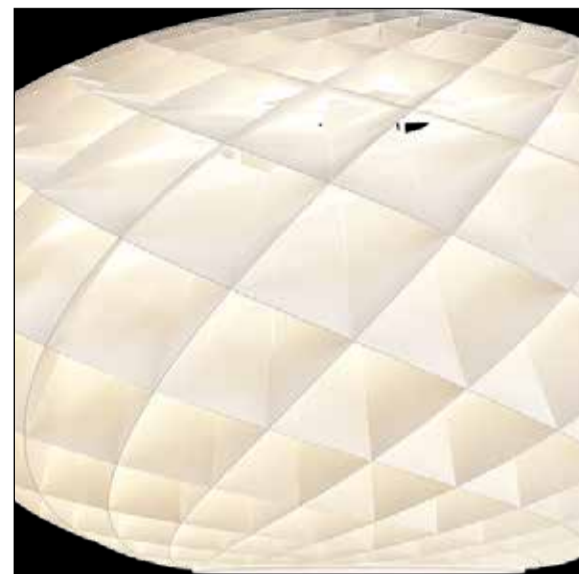

Patera Oval 500 LED

louis
poulsen

Design Øivind Slaatto

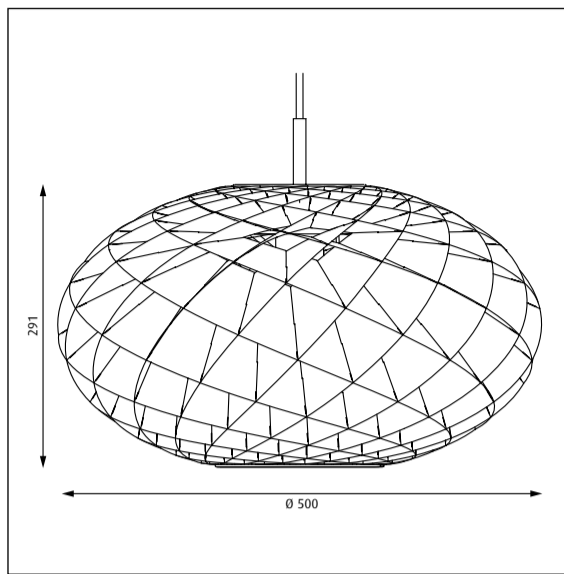

Lyskilde Light source Leuchtmittel Ljuskälla Sorgenti luminose Source lumineuse Fuente de luz Valonlähde	Spænding/frekvens Voltage/frequency Spannung/frequenz Spänning/frekvens Tensione/frequenza Voltage/frequence Tensión/frecuencia Jännite/taajuus	Vægt Weight Gewicht Vikt Peso/ingombro Poids Peso Paino	Isolationsklasse Electric shock protection Schutzklasse Isolationsklass Classe di isolamento Protection au choc électrique Clase de aislamiento Eristysluokka	Tæthedsklasse Ingress protection Schutzart Kapslingsklass Grado di protezione Indice de protection Clase de protección Kotelointiluokka
LED	 220-240V / 50/60Hz	Max. 3 kg	Cl. I	IP 20

DA

Støv aftørres med en tør, blød klud. Fedtpletter og lignende kan fjernes med en blød klud opvredet i lunkent vand (<50° C) tilsat mildt rengøringsmiddel. Brug aldrig rengøringsmidler med slibemiddel eller opløsningsmidler. Støv på lamellerne fjernes med en tynd støvekost gennem åbningerne eller med oliefri trykluft.

EN

Wipe off dust with a dry, soft cloth. Remove greasy spots etc. with a soft cloth dampened in lukewarm water (<50° C) with a mild detergent. Never use detergents containing abrasives and solvents. Use a thin brush through the openings or use oil free compressed air to remove dust from the lamellae.

DE

Staub bitte mit einem trockenen, weichen Lappen abwischen. Fettflecke und dgl. mit einem feuchten, in lauwarmem Wasser (<50° C) mit mildem Reinigungsmittel ausgewrungenen Lappen entfernen. Niemals Reinigungsmittel mit Schleifmittel oder Lösungsmittel verwenden. Staub auf den Lamellen wird durch die Öffnungen mit einem dünnen Staubwedel oder mit ölfreie Druckluft entfernt.

SV

Lampan dammtorkas med en torr, mjuk trasa. Fettfläckar tas bort med ljummet vatten (<50° C) utblandat med mildt rengöringsmedel. Använd aldrig rengöringsmedel som innehåller slipmedel eller lösningsmedel. Damm på lamellerna avlägsnas med en tunn dammvippa genom öppningarna eller med oljefri tryckluft.

IT

Pulire la polvere esterna con un panno morbido e asciutto. Rimuovere macchie di grasso ecc. con un panno morbido inumidito in acqua tiepida (<50° C) e con un detergente leggero. Non usare mai detersivi contenenti abrasivi o solventi. Per rimuovere la polvere dalle fasce, utilizzare una spazzola sottile tra le aperture o utilizzare dell'aria compressa.

FR

Essuyez la poussière avec un chiffon sec et doux. Enlevez les points de saleté etc. avec un chiffon doux imprégné d'eau claire tiède et de détergent doux. Ne jamais utiliser de détergents contenant des abrasifs et des solvants. Utiliser un pinceau fin à travers les ouvertures ou utiliser de l'air comprimé sans huile pour enlever la poussière des rainures.

ES

Limpiar con paño seco y suave. Quitar manchas de grasa y otras con paño suave humedecido con agua templada (<50° C) con detergente poco agresivo. Nunca use detergentes que contengan abrasivos y disolventes. Use un cepillo fino o aire comprimido exento de aceite para quitar el polvo de las aperturas en las clemas.

FI

Pyyhi pölyt kuivalla pehmeällä liinalla. Poista rasvatahrat miedolla pesuaineella ja haalealla vedellä (<50° C) kostutetulla pehmeällä liinalla. Älä koskaan käytä liuottimia tai hankausaineita sisältäviä pesuaineita. Lamelleihin kertynyt pöly pyyhitään väliköiden kautta kapealla pölyhuiskulla tai poistetaan öljytön paineilma.

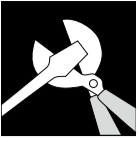

	L	⊕	N	DA +	DA -
DA	Brun	Gul/Grøn	Blå	Grå	Sort
SV	Brun	Gul/Grøn	Blå	Grå	Svart
EN	Brown	Yellow/Green	Blue	Grey	Black
DE	Braün	Gelb/Grün	Blau	Grau	Schwarz
IT	Marrone	Giallo/Verde	Blu	Grigio	Nero
FR	Brun	Jaune/Vert	Bleu	Gris	Noir
ES	Marrón	Amarillo/Verde	Azul	Gris	Noir
FI	Ruskea	Keltainen/Vihreä	Sininen	Harmaa	Musta
KR	브라운	옐로우/그린	블루	보라색	회색
CN	褐色	黄色/绿色	蓝色	紫色	灰色

	+	-
DA	Brun	Blå
SV	Brun	Blå
EN	Brown	Blue
DE	Braün	Blau
IT	Marrone	Blu
FR	Brun	Bleu
ES	Marrón	Azul
FI	Ruskea	Sininen
KR	브라운	블루
CN	褐色	蓝色

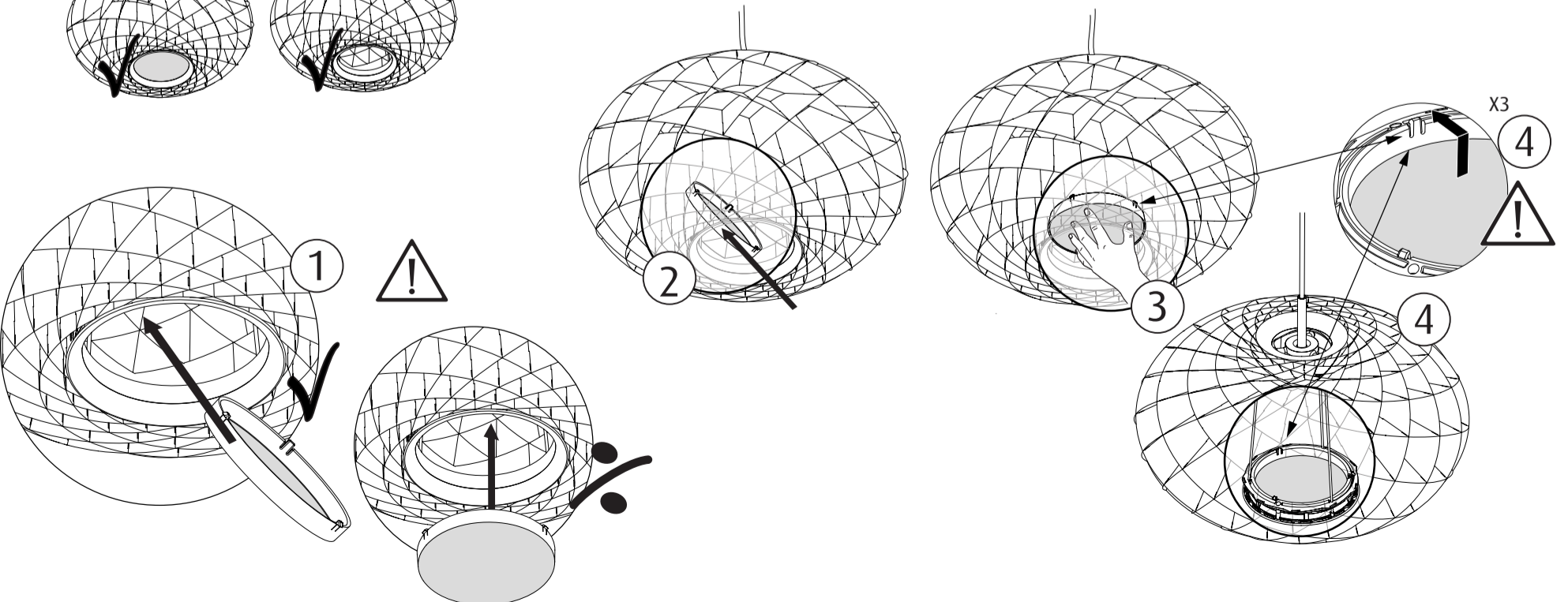
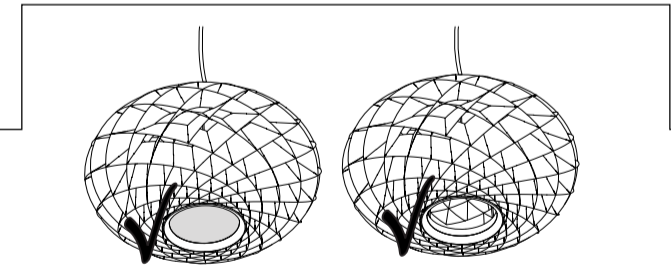
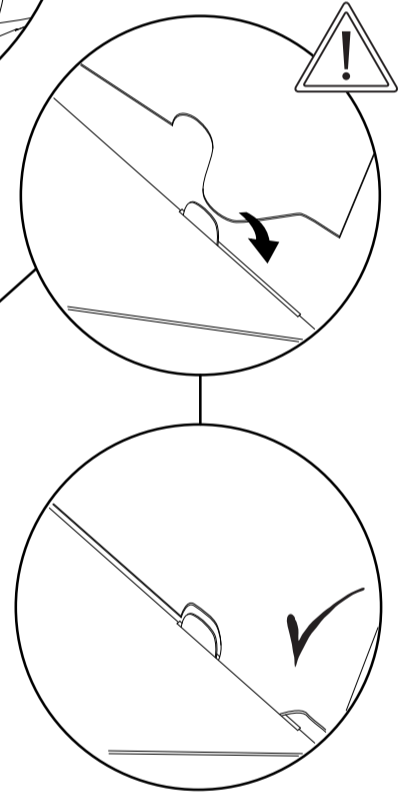
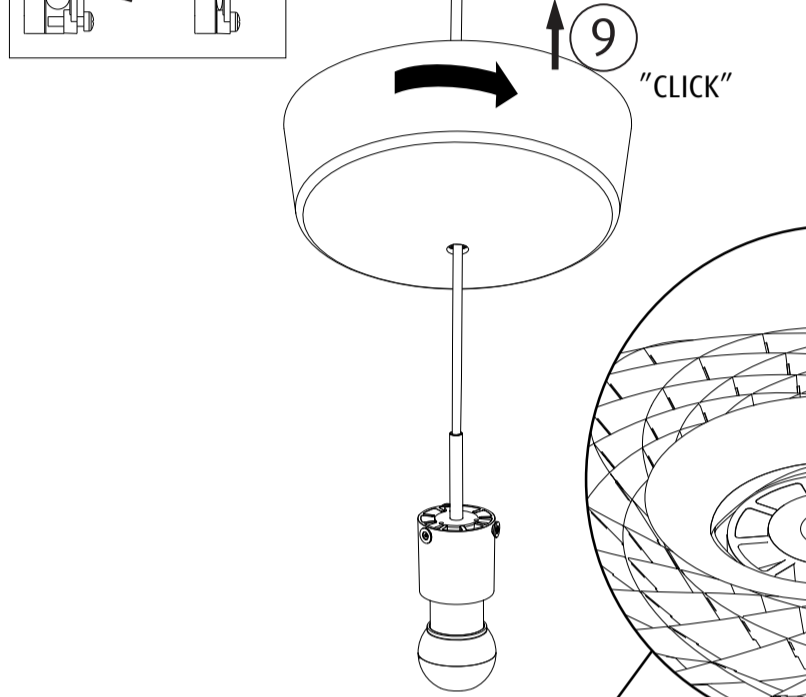
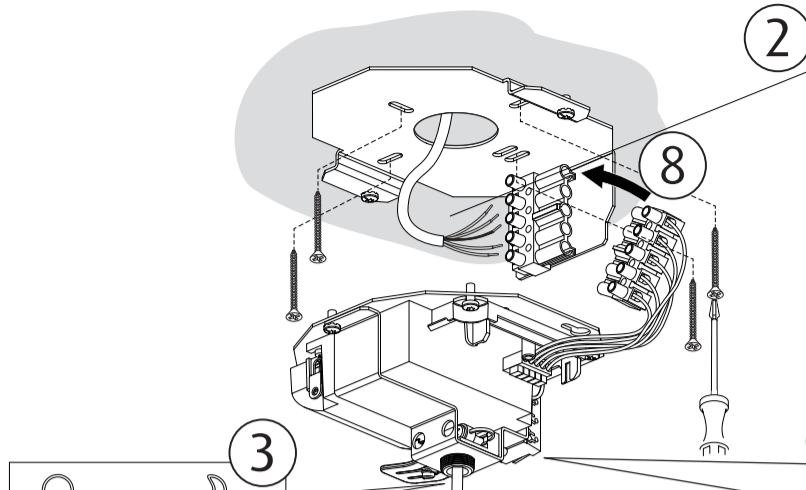
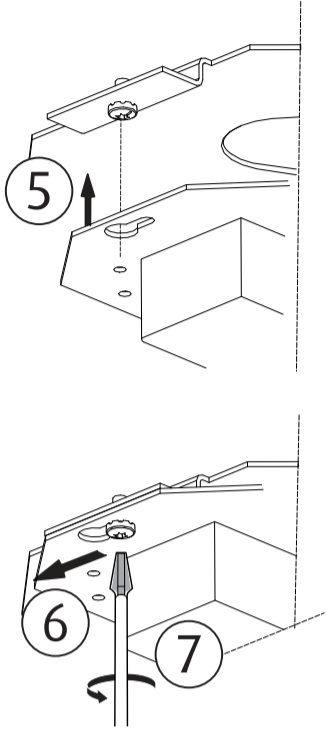



Replaceability & Energy Efficiency Class

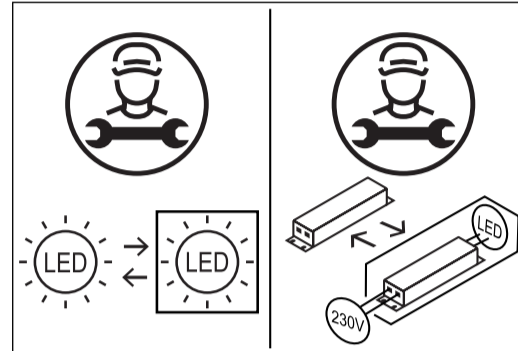

DA
Dette produkt indeholder en lyskilde i energieffektivitetsklasse E

EN
This product contains a light source of energy efficiency class E

DE
Dieses Produkt enthält eine Lichtquelle der Energieeffizienzklasse E

SV
Denna produkt innehåller en ljuskälla med energieffektivitetsklass E

IT
Questo prodotto contiene una sorgente luminosa di classe di efficienza energetica E

FR
Ce produit contient une source lumineuse de classe d'efficacité énergétique E

ES
Este producto contiene una fuente luminosa de la clase de eficiencia energética E

FI
Tämä tuote sisältää valonlähteen, jonka energiatehokkuusluokka on E



DA
Lyskilden i dette armatur må kun udskiftes af producenten eller en uddannet elektriker.



EN
The light source contained in this luminaire shall only be replaced by the manufacturer or a qualified electrician.



DE
Das in dieser Leuchte enthaltene Leuchtmittel sollte nur vom Hersteller oder von einem qualifizierten Elektriker ausgetauscht werden.



SV
Ljuskällan i denna armatur ska endast bytas ut av tillverkaren eller en kvalificerad elektriker.



IT
La sorgente contenuta in questa parte illuminante sarà solo riposizionata dal produttore o da un elettricista esperto.



FR
La source lumineuse de ce luminaire ne peut être remplacée que par le fabricant ou un électricien qualifié.



ES
La sustitución de la fuente de luz que contiene esta luminaria debe ser llevada a cabo exclusivamente por el fabricante o un electricista profesional.



FI
Tämän valaisimen valonlähteen saa vaihtaa ainoastaan valmistaja tai koulutettu sähköasentaja.