



HORM.IT

Specchi / Mirrors

# MAMANONMAMA—

Mario Botta, 2004

Die Kollektion Mamanonmama besteht aus fünf Blütenblättern, die sich an Margeriten inspirieren, zusammen oder einzeln platziert werden und entweder als Tisch- oder als Wandschmuck dienen können. Der massive Rahmen aus wertvollem schwarzem Weidenholz steht perfekt für die Philosophie der Horm Kollektionen.

**MAMANONMAMA** — Ispirata a una margherita, la collezione Mamanonmama è composta da cinque specchi a forma di petalo da disporre insieme o singolarmente su un tavolo o appesi a parete. La cornice, in prezioso legno massello di salice nero, si sposa alla perfezione con la filosofia delle collezioni Horm.

**MAMANONMAMA** — Inspired by daisies, the Mamanonmama (Love Me, Love Me Not) collection is composed of five petals to be placed, together or individually, on a table or on the wall. The frame, made of precious, black-willow solid wood, is perfectly attuned to the philosophy of Horm's collections.

**MAMANONMAMA** — S'inspirant de la marguerite, la collection Mamanonmama se compose de cinq pétales à disposer ensemble ou individuellement, posés sur une table ou suspendus au mur. Le cadre, en bois massif de saule noir de grande qualité, épouse parfaitement la philosophie des collections Horm.



### Misure e finiture / Sizes and finishes

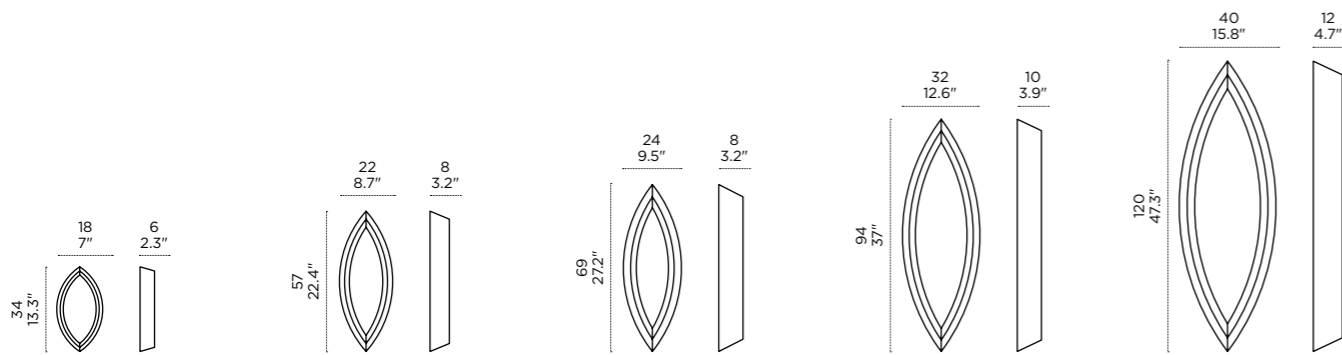

Download high resolution photographs of this product from [www.photos.horm.it](http://www.photos.horm.it)

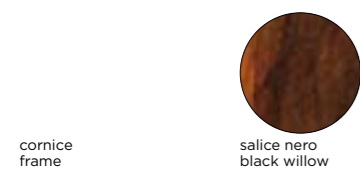

cornice  
frame

salice nero  
black willow





**BLEND**  
Armadio / Wardrobe

**MAMANONMAMA**  
Specchio / Mirror

**HI-PLY**  
Letto / Bed

**IO E TE**  
Comodino / Bedside Table

