

# SENDAI

design: Toyo Ito, 2004

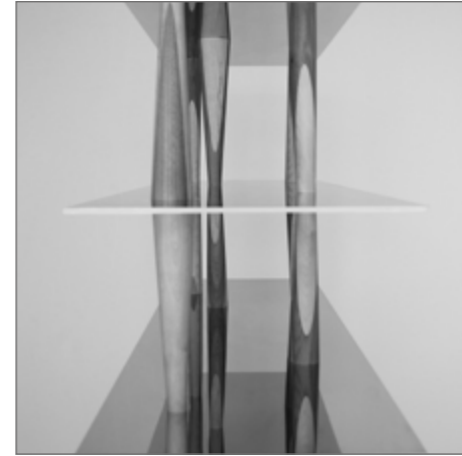

Libreria con ripiani in finitura alluminio lucido. Struttura formata da venticinque torniti di diverso diametro e inclinazione, in legno massello di alder e noce canaletto, trattati all'olio. Zoccolo in MDF laccato nero con piedini regolabili.

Bookcase with polished aluminium finish shelves. Structure composed of twenty-five turned wood elements, varying in diameter and at different angles, and made from solid alder and walnut, treated with oil. Black lacquered MDF plinth with adjustable feet.

Bibliothèque avec étagères avec finition en aluminium poli. Structure composée de 25 façonnages au tour de différent diamètre et de différente inclinaison, en bois massif d'aulne et de noyer noir, traités à l'huile. Socle en fibres de densité moyenne laqué noir, avec pieds réglables.

Bücherregal mit glänzenden aluminiumveredelten Einlegeböden. Der Korpus besteht aus fünfundzwanzig gedrechselten Pfosten von unterschiedlicher Größe und Neigung, hergestellt aus ölbehandeltem Massivholz aus Erle (Alnus) und Nussbaum. Sockel aus schwarz lackierter MDF-Platte mit verstellbaren Füßen.

Librería con estantes en acabado aluminio pulido. Estructura formada por veinticinco torneados de diferente diámetro e inclinación, de madera maciza de aliso y nogal negro, tratados al aceite. Rodapié de MDF lacado negro con pies ajustables.

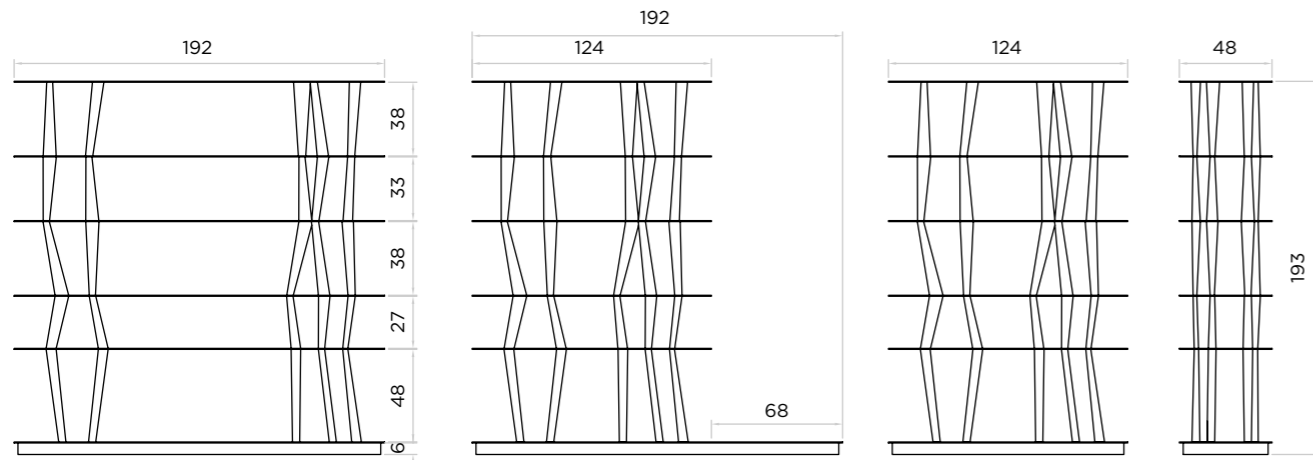

TORNITI TURNED TOURNÉE GEDREHT CONVERTIDO	massello di noce canaletto e alder solid walnut and alder wood noyer massif et de l'aulne nussbaum Massiv und erle nogal solido y el aliso
RIPIANI SHELVES ÉTAGÈRES BOEDEN ESTANTES	alluminio specchiato mirror finish aluminium miroir en aluminium Aluminium spiegel espejo de aluminio

	BV0502
	BV0506
	BV0504