

OW149-F | COLONIAL STOOL - Design: Ole Wanscher



DESCRIPTION

- The Colonial foot stool is an elegant yet sturdy stool which perfectly complements the Colonial Chair.
- The stool has the same outstanding finish as the Colonial Chair.
- It has a simple and light expression and can easily be moved around to serve other purposes as well.
- It also works beautiful alone in the hallway, bedroom or similar.
- It has an elegant and timeless expression with its visible solid wood frame and softly rounded cushions providing great comfort.
- The seat is made of hand woven cane and can be removed from the frame of the stool and replaced if so needed.
- The cushion consists of cold foam and can be upholstered in fabric or leather upon request.
- The cushion is turn-able in fabric - but not in leather.

HISTORY

- Designed by Ole Wanscher in 1949
- The foot stool was designed together with the Colonial Chair.

THE DESIGNER

Ole Wanscher (1903-1985), was born in Copenhagen in 1903 and was an architect and professor of architecture with furniture designs as his specialty. He came to shape Danish furniture, both as an active designer and as a master teacher. His furniture designs are now

considered to be modern classics - sophisticated and functional with an exquisite attention to detail.

Construction and form was of the utmost importance to **Ole Wanscher**, treating furniture design as if it was a branch of architecture. He studied under Kaare Klint at the Royal Danish Academy of Fine Arts and also worked for the master himself from 1924-1927, before becoming an independent architect specializing in furniture design. He later followed in Kaare Klint's footsteps as a professor at The Royal Danish Academy of Fine Arts with a master in furniture design.

In 1958, the Danish newspaper Politiken wrote the following about the outstanding quality and spirit of **Ole Wanscher's** products: 'Owning a Wanscher-chair is an adventure every day, and will be so even several hundred years from now, for this is how long it lasts.'

Ole Wanscher created his best known products primarily in the period between the late forties and early sixties. He took great interest in industrially produced high quality furniture and designed several pieces with this particular aspect in mind. It was the familiar philosophy of 'design for everyone'. However, his finest work was made in close collaboration with renowned master cabinetmakers.

Furthermore, while traveling through Egypt and Europe, **Ole Wanscher** studied furniture design. He embraced these impressions, was inspired by them and brought to them his very own sensibility. He also authored several books, including "The History of the Arts of Furniture" and "Five Thousand Years of Furniture".

Characteristic of **Ole Wanscher's** design is a quest for slim dimensions and resilient forms. His chairs often employ both slender and slightly curved armrests, which rise in an elegant tip before continuing directly to the floor; as is the case with his well known **Colonial Chair**. Classic and yet singularly modern at the same time.

Experience Ole Wanscher's Colonial Chair

Watch the craftsmanship going into the making of the Colonial Chair

VARIANTS CHOICES AND DIMENSIONS

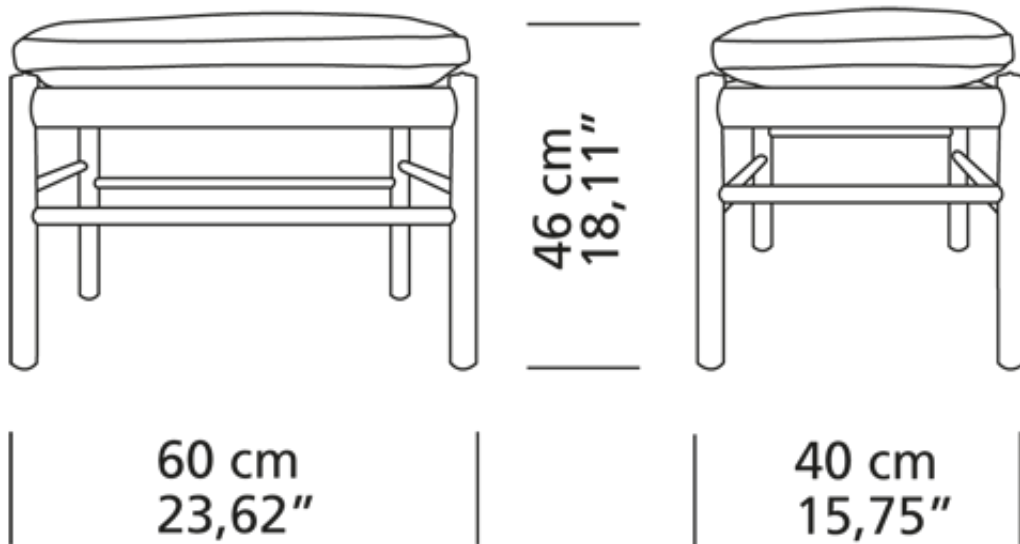

MATERIAL MATRIX

	Soap	Lacquer	White oil	Oil	Black paint
Oak	●	●	●	●	●
Walnut		●		●	

Oak and ash have a clearly visible wood structure when painted. Beech has minimal structure when painted.

ENVIRONMENTAL INFORMATION

Carl Hansen & Søn and sustainability

People's fascination of the combination of good design and wood, as well as other natural materials, is something that transcends time and fashion. At Carl Hansen & Søn, we believe that this fascination helps to explain the great interest in our furniture, and we take very seriously concerns about the sustainability of the natural resources upon which we depend for our products. That is why we strive every day to improve our production methods, logistics and sales efforts in respect of scarce natural resources.

We buy wood only from sustainably managed forests. All sourced wood meets EUTR 2013 regulations, Danish Forest Legislation and current international certifications. Oak, beech and ash come primarily from Danish forests which are managed according to the principles described in Denmark's National Forest Programme; some of these wood types are also sourced from other similarly managed European forests, or, in the case of walnut and cherry, North American forests.

We use every possible bit of these fine hardwoods in our furniture production. Inevitably, however, there are some scraps, which are then used to produce other products or recycled in district heating plants.

TESTS AND CERTIFICATIONS

All tests and certificates are available on request.

CONTACT INFORMATION

EUROPE

Carl Hansen & Søn A/S

Hylkedamvej 77-79

DK 5591 Gelsted

Denmark

Tel: +45 66 12 14 04

info@carlhansen.com

Carl Hansen & Søn Flagship Store

Bredgade 18, 21 & 23

1260 Copenhagen K

Denmark

Opening Hours:

Monday-Friday: 11.00-18.00

Saturday: 10.00 - 15.00

Phone: +45 64 47 23 60

retail@carlhansen.dk

Carl Hansen & Søn Showroom Oslo

Drammensveien 130 B9

0277 Oslo

Norway

+47 900 77 087

hrs@carlhansen.dk

Carl Hansen & Søn Showroom London

16A Bowling Green Lane

London

EC1R 0BD

United Kingdom

Tel: +44 (0) 20 7632 7587

Mail: ukinfo@carlhansen.com

Carl Hansen & Søn Italy SRL

Showroom Milan

Foro Buonaparte 18/A/ Via Arco 4
20121 Milan
Tel: +39 02 89011837

Area Manager Southern Europe
Ottorino Castegnaro
Tel: +39 340 4266636
Mail: oc@carlhansen.dk

AMERICA

Carl Hansen & Søn, Corp.

251 Park Avenue South
13th Floor
New York, NY 10010

Tel: +1 212 242 6736

Customer Service: Northamerica@carlhansen.com

Contract Sales:

[Contract contact information US](#)

Thomas Vagner, President: tv@carlhansen.com

Angela Patsiopoulos, Director of Retail Sales: ap@carlhansen.com

Carl Hansen & Søn Showroom Los Angeles

8745 Washington Boulevard
Studio B
Culver City, CA 90232
Tel.: + 1 (310) 842-8656

ASIA/PACIFIC

Carl Hansen & Søn Japan K.K.

2F Hills Aoyama, 3-39-9 Jingumae
Shibuya-ku 150-0001
Tokyo, Japan

Tel: +81 3 5413 6771

Fax: +81 3 5413 6772

info@carlhansen.jp

Carl Hansen & Søn Flagship Store Japan

Aoyama Artworks 1/2F
2-5-10 Jingumae
Shibuya-ku, Tokyo, 150-0001
Japan

+81 3 5413 5421

Opening hours

Mon-Fri: 11 am- 8 pm

Sat. Sun. and

National Holidays: 12 a m - 7pm

Carl Hansen & Søn Asia Pacific Limited

16th Floor, 202 Centre

202-204 Des Voeux Road West

Hong Kong

Tel: +852 563 10267

Mail: asiainfo@carlhansen.dk

Carl Hansen & Søn China

570 Yongjia Road, Surpass Court Building 5 Room 501

Xuhui District, Shanghai

China, 200030

Tel: +86 15000390978

Mail: chinainfo@carlhansen.dk