



DESCRIPTION

The CH56&CH58 barstool is perfect for the modern open kitchen space. It also offers obvious solutions for the contract market, especially for bar- and dining areas.

It is a light barstool and thereby easy to move around the room.

Its rounded lines and mix of three materials, wood, steel and leather, gives the stool a very modern expression.

The round metal ring ensures both stability and comfort as it is an obvious place to rest ones feet.

The barstool consists of solid wood legs, stainless steel and a seat upholstered in the customer´s choice of leather.

ENVIRONMENTAL INFORMATION

Carl Hansen & Søn and sustainability

People's fascination of the combination of good design and wood, as well as other natural materials, is something that transcends time and fashion. At Carl Hansen & Søn, we believe that this fascination helps to explain the great interest in our furniture, and we take very seriously concerns about the sustainability of the natural resources upon which we depend for our products. That is why we strive every day to improve our production methods, logistics and sales efforts in respect of scarce natural resources.

We buy wood only from sustainably managed forests. Oak, beech and ash come primarily from Danish forests which are managed according to the principles described in Denmark's National Forest Programme; some of these wood types are also sourced from other similarly managed European forests, or, in the case of walnut and cherry, North American forests.

We use every possible bit of these fine hardwoods in our furniture production. Inevitably, however, there are some scraps, which are then used to produce other products or recycled in district heating plants.

CONTACT INFORMATION

Europe

Carl Hansen & Søn Møbelfabrik A/S
Holmevænget 8
5560 Aarup
Denmark

Tel: +45 66 12 14 04
Fax: +45 65 91 60 04
info@carlhansen.com

Carl Hansen & Søn flooring store

THE DESIGNER

Hans J. Wegner was born in 1914 in Tønder, the son of a shoemaker. At the age of 17 he was apprenticed to a carpenter (H. F. Stahlberg) and it was at this time that he developed his first design. At the age of 20 he moved to Copenhagen to study at the institution now known as The Royal Danish Academy of Fine Arts, School of Design but which back then went under the more modest title of "The Artisan College."

He studied there from 1936-1938, before taking further studies as an architect. In 1940 Wegner initiated a joint project with Arne Jacobsen and Erik Møller in Aarhus, which involved fitting out Aarhus' town hall. It was also in 1940 that Wegner began to work with Master Carpenter Johannes Hansen, a man who played a significant role in bringing modern design to the Danish public. The then Copenhagen Industrial Art Museum (now Design Museum Denmark) purchased their first Wegner chair in 1942. Hans J. Wegner opened his own design studio in 1943, and in 1944 he designed his first "China Chair" in a series inspired by the Chinese Emperor's thrones.

One of the chairs in this series is what is probably Wegner's most famous work "The Wishbone Chair," which he designed in 1949, and which Carl Hansen & Søn have manufactured since 1950. Hans J. Wegner is regarded as one of the world's outstanding furniture designers. He was one of the motive forces behind the Danish Modern movement which did much to change people's view of furniture in the 1950s and 60s. His design retain relevance for us today and his sense for details is a source of constant wonder.

Wegner has received a number of prizes and recognitions. Amongst other things, he is an honorary member of The Royal Danish Academy of Fine Arts and has received an honorary doctorate from the Royal College of Art in London. He was also the first ever recipient of the Lunning Prize and received the 8th International Design Award in Osaka, Japan. His works are exhibited at major international museums including The Museum of Modern Art (MoMA) in New York and Die Neue Sammlung in Munich.

Hans J. Wegner died in Denmark in January 2007

Hans J. Wegner's contributions to Danish design:

- A master carpenter first and a designer second: Perfectly finished joints and exquisite forms.
- A deep respect for the wood and its character and an everlasting curiosity about good materials.
- He gave minimalism an organic and natural softness.
- He is considered as "the master chair-maker" and designed more than 500 chairs during the course of his life.

Carl Hansen & Søn flagship store
Bredgade 21
1260 Copenhagen K

Opening hours:
Monday-Friday: 11am - 6pm
Saturday: 11am - 4pm, Sunday: 12am-3pm
Phone: +45 64 47 23 60

Rud. Rasmussen
Nørrebrogade 45
2200 Copenhagen N

Sales office London
Carl Hansen & Søn
12-16 Clerkenwell Road
London EC1M 5PQ
United Kingdom
+44 (0) 207 324 6258

Asia/Pacific
Carl Hansen & Søn Japan K.K.
Kojimachi Duplex B's 10F
4-4-7 Kojimachi Chiyoda-ku,
102-0083 Tokyo
Japan

Tel: +81 03 3265 4626
Fax: +81 03 3265 4627
info@carlhansen.jp

America
Carl Hansen & Søn Inc.
462 Wellington St., West
Suite 502
Toronto, ON M5V 1E3
Canada

Carl Hansen & Søn Corp
304 Hudson Street
3rd Floor
New York, NY 10013
USA

Tel: +1 212 242 6736
Fax: +1 (416) 572-4073
northamerica@carlhansen.com

VARIANTS CHOICES AND DIMENSIONS

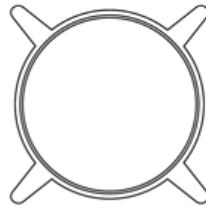
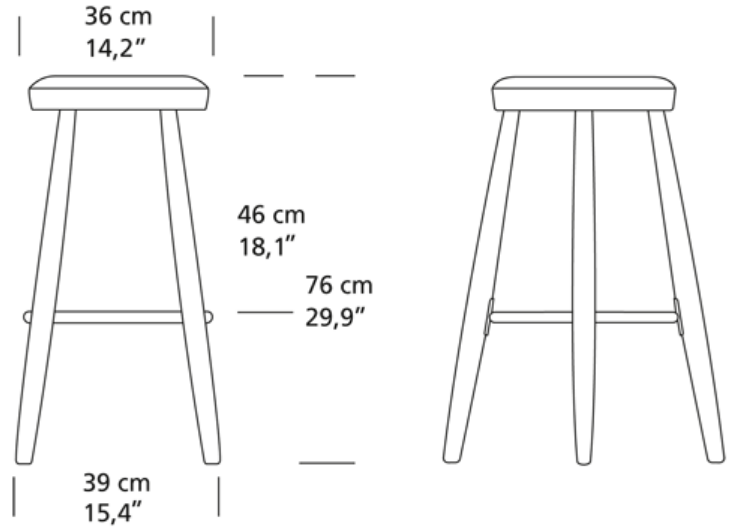

MATERIAL MATRIX

	Soap	Lacquer/Oil	White oil	Black paint	CHS stain
Oak	●	●	●	●	●
Walnut		●			

TESTS AND CERTIFICATIONS

All tests and certificates are available on request.